

RADIO CIRCUIT HANDBOOK

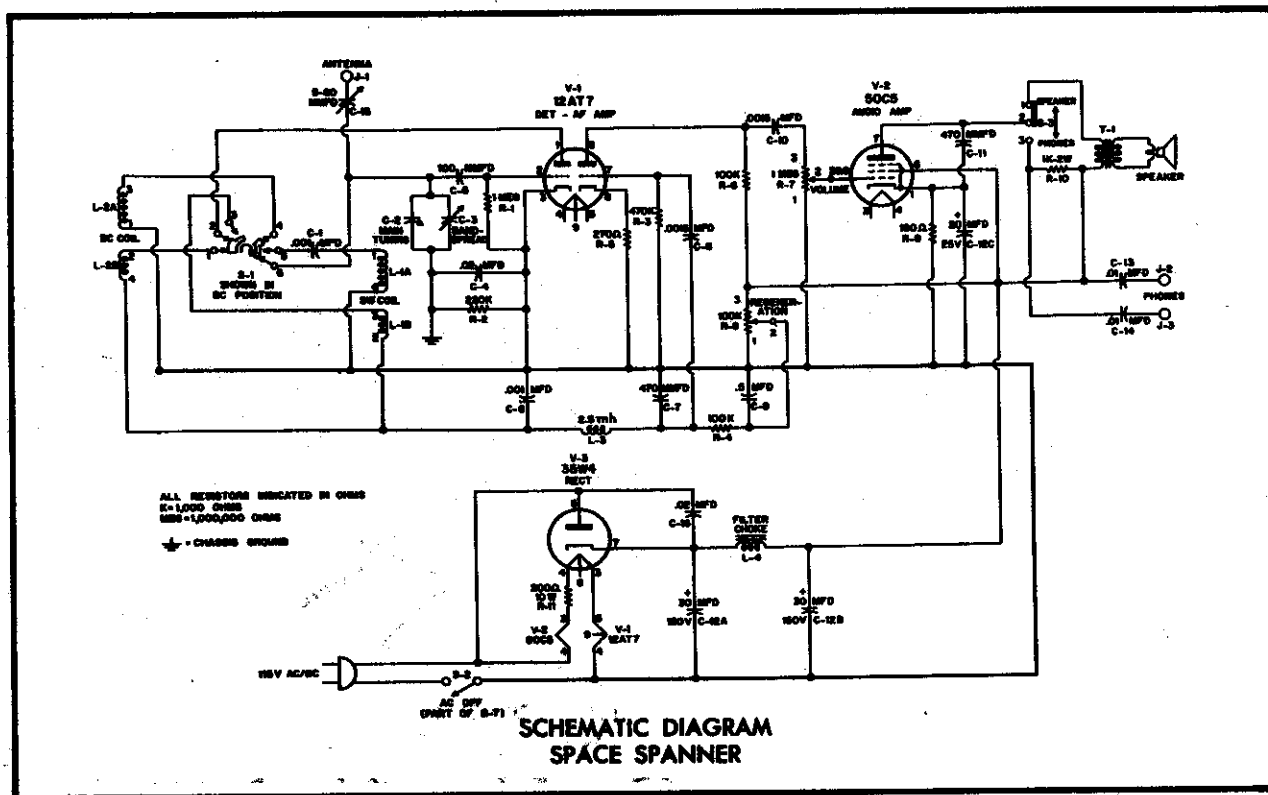

Knight-Kit AC-DC "Space Spanner"

THE "Space Spanner" circuit illustrates the versatility and operating convenience that can be built into a simple AC-DC receiver. The basic circuit is the extremely efficient, highly sensitive, regenerative type — similar to that used in the "Ocean Hopper"; but with such added refinements as bandswitching and an added stage of audio amplification.

This receiver will provide excellent reception of broadcast and short-wave transmissions through the built-in speaker or through headphones. It covers the entire broadcast band from 540 to 1700 kilocycles — and by turning the bandswitch to the shortwave position it covers the international and Amateur short-wave bands between 6 and 17 megacycles. These include the 40 and 20 meter Amateur bands, and the 49, 41, 40, 31, 25, 20, and 19 meter international bands. When used with an efficient antenna system, this receiver will bring in stations from "all corners of the earth" with amazing clarity. Local broadcast reception is possible with only a few feet of antenna wire strung around the room.

The filament wiring and power supply of the "Space Spanner" are conventional. As the total voltage drop of the tubes (wired in series) is only 97.6 volts, a 200 ohm dropping resistor is used to permit operation from a 110-120 volt AC or DC source. A type 35W4 halfwave rectifier is used in the power supply. The large electrolytic capacitors and the filter choke smooth out AC ripple to reduce hum to a minimum.

The type 12AT7 is actually two triode tubes in a single envelope. Except for a common heater, they operate independently of each other. One section functions as a highly efficient regenerative detector, and the other as a high gain stage of audio amplification. Separate antenna coils are used; L-2 for broadcast, and L-1 for shortwave reception. The position of the band switch, S-1, determines which coil is connected in the circuit. Each coil has two separate windings; the "A" section is the grid circuit winding, and the "B" section is the plate circuit winding. The "A" section of the coils with the main and bandspread tuning capacitors make up a "tank" which

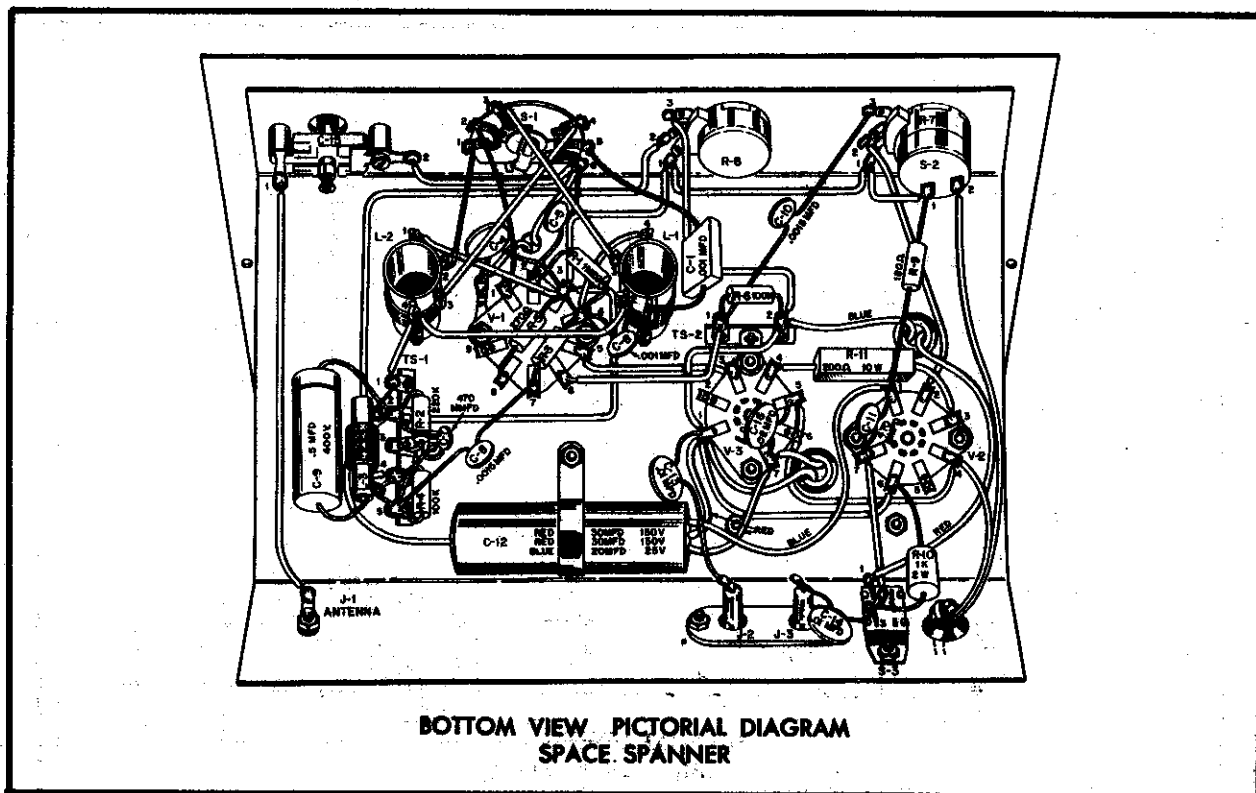

Knight-Kit AC-DC "Space Spanner"

can be resonated to any frequency within the range of the coil in use. This is how the receiver is tuned. For broadcast reception, only the main tuning capacitor is used. On shortwave the main tuning capacitor is used to locate the approximate range or frequencies to be covered and the bandspread capacitor is used to pick out a particular station. In operation, the antenna control is adjusted for best results with the antenna being used and the frequency being received.

Incoming RF signals, with the exception of the frequency to which the "tank" is tuned, present a low impedance and are shunted to ground. The desired signal is fed to the grid of the 12AT7 and detected in the grid-cathode circuit. The detected signal, now an audio frequency, travels through the plate circuit and is fed through C-8 to the grid of the second section of the 12AT7. A portion of the original RF signal appearing at the detector grid of the tube is amplified in the plate circuit. This RF appears in the "B" section of the antenna coil and is inductively

coupled back into "tank" circuit, thus producing regeneration as the signal is fed back into the grid of the tube. The RF choke which allowed the audio frequency to pass, opposes the flow of RF and keeps it from the power supply and the audio section of the receiver. The amount of regeneration is controlled by a potentiometer that varies the detector plate voltage.

The audio portion of the signal is amplified in the second section of the 12AT7 and is coupled through C-10 and the volume control to the 50C5 power amplifier. The 50C5 is capable of delivering approximately 2 watts of audio power—more than enough for loudspeaker reproduction. The speaker-headphone switch, S-3, permits operation with the built-in speaker or with headphones. Capacitors C-13 and C-14 isolate the headphone jacks from the DC voltage present in the plate circuit of the 50C5.

The Knight-Kit "Space Spanner" radio in kit form, complete with all parts, tubes and hardware, is listed in the kit section of the Allied Radio catalog.